

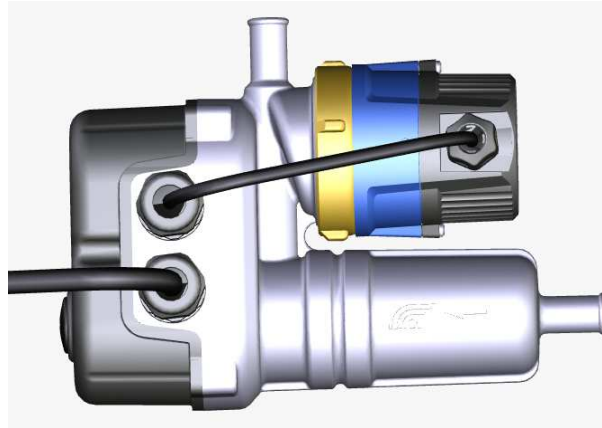

CARLOR
ENGINEERING

**USER GUIDE
FLOWSTART
Ref. FS
From 0,5 to 2 kW**

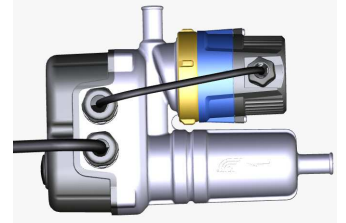

FlowStart is a compact electric coolant heater with circulating pump for generating sets, marine engines and all types of vehicles located inside or outside (protected place only).

TABLE OF CONTENTS

1. IMPORTANT SAFETY INSTRUCTIONS: page 2

2. SPECIFICATIONS

Technical Characteristics: page 3

Exploded view: page 3 and 4

3. MOUNTING INSTRUCTIONS

Unpacking and installation preparation: page 4

Precautions: page 4

Installation instructions: page 4

Connecting the coolant circuit: page 5

Electrical connections: page 5

4. DIRECTION FOR USE

Putting the heater into service: page 6

Resetting the safety thermostat: page 6

5. TROUBLESHOOTING: page 6

6. INSTRUCTIONS FOR THE PROTECTION OF THE ENVIRONMENT: Page 7

7. TOTAL QUALITY : page 7

8. WARRANTY: page 7

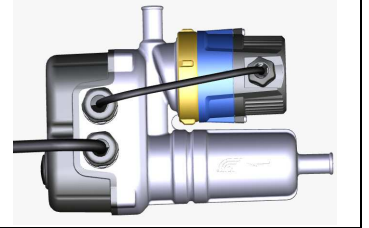

The present user's guide contains instructions to be fulfilled during the mounting and the starting stage. Please read carefully for a correct installation and a proper use of the heater. Keep these instructions after installation.

1. IMPORTANT SAFETY INSTRUCTIONS

Qualified personnel

The mounting should be carried out by a qualified technician only.

Danger in case of non-compliance with the present guidelines

The non-compliance with present guidelines could have serious consequences for the safety of people and could damage the equipment, thus making the warranty void. The strictest rigor is required for the electrical and mechanical aspects of the mounting.

Safety measures meant for the user

Avoid any risks linked to the mains by strictly observing local safety instructions in force.

Check or have checked by an authorized technician that your electrical installation is protected by a differential current system and that the earthing is in compliance with the local safety prescriptions.

Modifications to the heater and use of unauthorized parts

Any modification to the heater will be made only in agreement with the manufacturer. The use of official spare parts and accessories guarantees your safety. The manufacturer disclaims any liability in case non-original parts are used.

Inappropriate use of the equipment

The equipment supplied with the present user guide is exclusively meant for the applications described in this user guide.

The FlowStart is a universal and compact electric coolant heater with circulating pump. It can be used to heat engines in generating sets, marine, industrial applications and all types of vehicles located inside or outside.

The FlowStart is not made to be installed in an explosive environment.

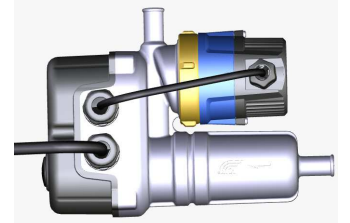

2. SPECIFICATIONS

Technical Characteristics

The FlowStart is a universal and compact electric coolant heater with circulating pump. It can be used to heat engines in marine and industrial applications (generating sets) and all types of vehicles located inside or outside. High-quality components and materials are used to guarantee the reliability of the heater. Its compactness makes it easy to install. The heater is made of a heating body, a heating element, a fixed regulating thermostat, an overheat thermostat with manual reset (option) and a circulating pump.

As soon as the heater is plugged in, the coolant of the engine is sucked into the heating body and then expelled by the pump back into the engine. The pump allows a progressive and uniform warming of the engine. The thermostat controls the heating element (and eventually the pump). The safety thermostat (option) protects the heating element and the pump in case of overheating.

Components characteristics	
Electrical characteristics	
Voltage and Frequency	120V-60Hz or 230V-50 Hz
IP Class	Standard IP44 (Higher IP level possible)
Power/Voltage	500W / 1000W / 1500W / 2000W (230V), 500W / 1000W / 1500W (120V)
Pump Power	2,5-9W
Current draw	from 2,2 to 12,6 Amp. depending models
Working specifications	
Maximum working pressure	10 bars (150psi)
Pump working temperature range	-10°C -> 95°C (coolant)
Regulation thermostat range	Fix 35-50°C (95-122°F) or 34-40°C (93-104°F)
Safety thermostat	110°C with manual reset (Optional)
General characteristics	
Weight in kg	2,6 kg

Exploded view FlowStart

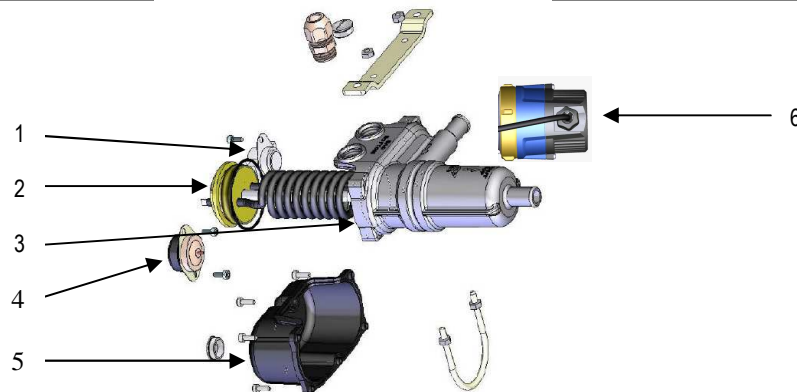

1. Regulation thermostat

25 Amp cutting capacity (100000 cycles). Regulation thermostat with fixed temperature range:

- ✓ ON 34°C. – OFF 40°C (93-104°F)
- ✓ ON 35°C. – OFF 50°C (95-122°F)

2. Heating element

Voltage: 120VAC, 208VAC or 230 VAC.

Power: from 500 to 2000 Watts.

Heating element formed in spiral with ultra low wattage density (7,5 W/cm²-> 1,5kW) and Incoloy 800® stainless steel protection

3. Heating body in aluminum

4. Safety thermostat (optional)

Safety thermostat with manual reset, temperature limit at 110°C (230°F) and 25 Amps cutting capacity.

5. Protection cap in polyamide

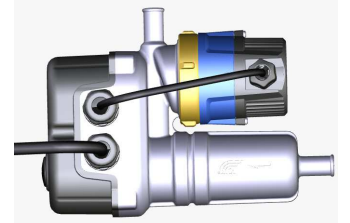

Exploded view FlowStart (cont)

6. Wet rotor pump Vortex BWO 155

Voltage: 120-230 VAC.
Frequency: 50-60 Hz
Flow rate in the enclosed table
Power: 2,5-9W

Q/H GRAPH BWO 155



3. MOUNTING INSTRUCTIONS

Unpacking and installation preparation

Make sure you have the following components and accessories before disposing of the packaging material:
For a correct installation use the spare parts and accessories delivered with the FlowStart.

1. **Heater FlowStart**
2. **Connection kit**
 - 1 Mounting bracket
 - 1 Mounting clamp collar
 - 4 Nuts M6



Precautions

The installation has to be made by an authorized technician in strict compliance with the instructions of the manufacturer. **NEVER** connect to the mains before having followed the present instructions. Do not connect the heater to the mains if you are not sure that it is filled with coolant.

Installation instructions

- ✓ The FlowStart should be mounted in horizontal position. In no circumstances should the axis of the pump be placed in a vertical position.

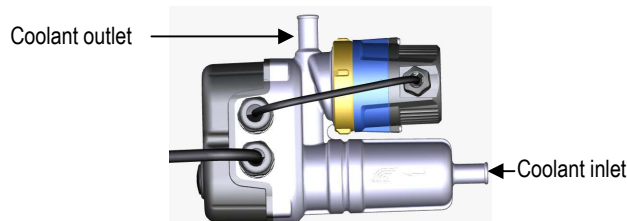

- ✓ Fix the heater as low as possible. The heater should be below the lowest level of the water jacket and the coolant inlet must be below the point of removal of the coolant from the engine.
- ✓ Fix the FlowStart to the chassis or any other suitable place with the fixation kit supplied with the heater. If you don't use fixation kit supplied, the support for the fixing of the heater should be rigid enough.
- ✓ Select a mounting location that allows to reduce the length of the tubing to a minimum.
- ✓ Be careful not to mount the heater, the hoses or the power cord close to the engine exhaust.

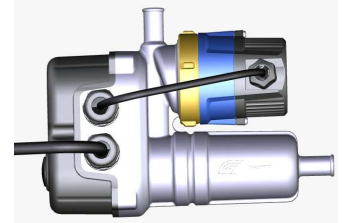

Connecting the coolant circuit

Drain off completely the coolant circuit.

Before placing the heater, it is imperative to drain the coolant circuit. Unscrew the drain plug or disconnect the lower hose in order to completely drain off the coolant circuit.

Connecting the heater inlet and outlet.

The heater inlet and outlet are meant for hoses (not supplied) with an internal diameter of 5/8" (16 mm). For engines equipped with a drain plug, replace the plug by a hose connector with an internal diameter of 16 mm in order to make the connection to the heater inlet. If the heater is connected to a rigid pipe, use a piece of flexible radiator hose that is long enough to prevent engine vibrations being transmitted to the heater. In order to guarantee an optimum heating of the engine the coolant return hose from the heater to the engine should be placed at the highest possible point on the engine and as far as possible from the suction port to enhance heat distribution throughout the engine.

Checking and re-filling the coolant circuit

Make sure that the hose clamp collars are properly tightened. Fill the coolant circuit with a high quality and clean mixture glycol/water without impurities and without exceeding the recommended proportion 50% glycol / 50% water. It is necessary to check its quality frequently to ensure that the heater is not dirty, has no grimes and does not suffer from deterioration. The life and the proper functioning of the heater depend on it. In order to eliminate air pockets and obtain a good circulation, run the engine a few minutes. Then shut off the engine and check that the water circuit is properly flushed. Check that all connections are watertight and that hose clamps are properly tightened. When the engine has cooled down, check the level of coolant in the circuit and adjust if necessary

Example of correct installation

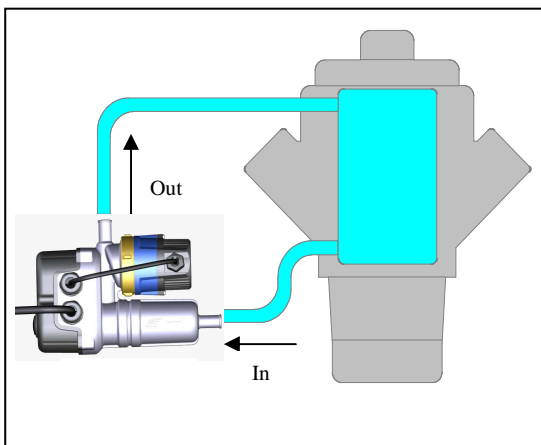

Example of wrong installation

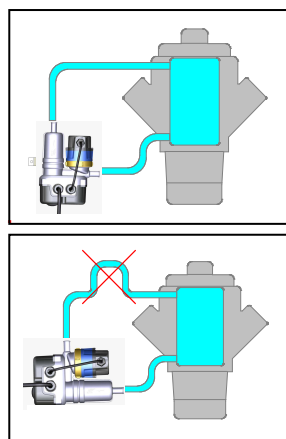

Horizontal mounting is not correct

Curve in the tubing

Electrical connections

Fixing the power supply cord.

Fix the cord with clamp collars in order to avoid any contact with hot or moving parts. It is recommended to use a protection sheath for the cord.

Checking the installation before connecting the heater to electricity.

Check the information regarding voltage and power on the heater label before connecting the heater to electricity. An improper connection to the mains could irretrievably damage your heater. Make sure that the voltage is correct and the earthing is in compliance with local rules.



Electrical diagrams: FlowStart 120V – 208V – 230V 50 / 60 Hz

- A. NC regulation thermostat (35-50°C or 34-40°C)
- B. NC 110°C safety thermostat with manual reset (Option)

- C. Heating element
- D. Circulation pump

Configured such that the pump switches off with heating element (ex: FS 230 1 2000 35-50 M)

Configured for continuous pump operation (ex: FS 230 1 2000 35-50 M C)

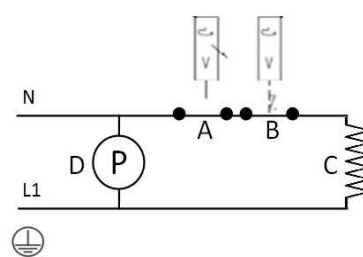
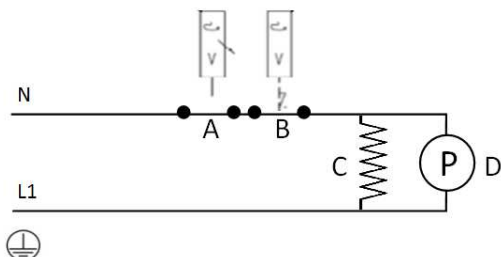

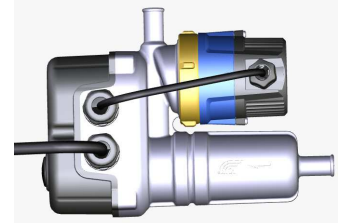

4. DIRECTIONS FOR USE

Putting the heater into service

BEWARE: DON'T START THE HEATER IF NOT FILLED WITH COOLANT AND NEVER RUN THE PUMP WITHOUT LIQUID.

Follow the procedure described hereafter:

- Connect the plug.
- The regulating thermostat will adjust the temperature in the range from 34°C to 40°C (93° F to 104°F) or from 35°C to 50°C (95°F to 122°F).
- Touch the heater inlet and outlet hoses at regular intervals during one hour. If the heater works correctly, the outlet hose should be warm and the inlet hose relatively cold. If the inlet hose becomes very hot before the outlet hose, the circulation is not good.

Resetting the overheat thermostat (optional)

In case of overheating (due for example to a lack of water in the circuit), the overheat thermostat (option) is activated and cuts the power supply to the heating element. After having the system checked, the overheat thermostat has to be manually reset. In order to do this, unscrew the protection cap of the heater and push the reset button.

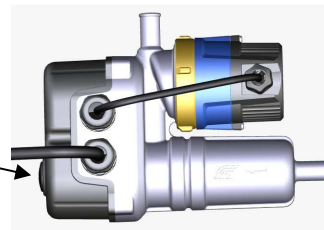

5. TROUBLESHOOTING

Before contacting the technical service, please check the following table for causes and remedies:

- Contaminated cooling circuit
- Air pocket caused by a curve in the hoses
- Engine temperature higher than the thermostat set temperature.

Type of problem	Possible causes	Control and remedies
The pump doesn't work. The heating body of the heater and the engine remain cold	The heater is not connected to the mains.	<ol style="list-style-type: none"> 1. Check that the supplying cable is connected to the mains. 2. Check that the supply to the mains is correct. 3. Check the fuses in the mains distribution box.
The pump works properly but the heating body of the heater and the engine remain cold	The overheat thermostat has been switched on. ⇒ Lack of water into the heater	<ol style="list-style-type: none"> 1. Disconnect the supplying cable from the mains. 2. Reset the overheat thermostat (see above) 3. Check the level of water in the circuit. 4. Adjust the level if necessary. 5. Turn the engine on for 10 minutes. 6. Reconnect the supplying cable to the mains
The pump works properly but the heating body of the heater and the engine remain cold	Failure of the heating element. Failure of the regulating thermostat.	<ol style="list-style-type: none"> 1. Put the heater out of service and call the technical service.
The connection to the mains is correct and the circuit is correctly purged. The heating body of the heater is hot but the engine remains cold.	Bad circulation. Pump blocked with impurities. The pump is not working.	<ol style="list-style-type: none"> 1. Unblock the pump. (Unscrew the motor and clean the rotor). 2. If unsuccessful, put the heater out of service and call the technical service.
The fuse or the circuit breaker in the distribution box is engaged.	Electrical breakdown.	<ol style="list-style-type: none"> 1. Put the heater out of service and call the technical service.



**USER GUIDE
FLOWSTART
Ref. FS
From 0,5 to 2 kW**

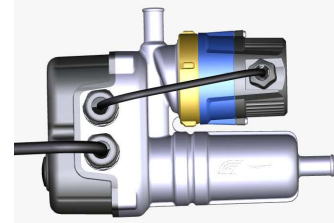

6. INSTRUCTIONS FOR THE PROTECTION OF THE ENVIRONMENT

Recuperation of raw materials rather than elimination of waste. Machines, as well as their accessories and packaging, should be recycled in an appropriate way. Our spare parts can be recycled selectively depending on the type of material. Carlor Engineering S.A. commits itself to recycle the different components of the FlowStart. Each FlowStart will be either reconditioned or recycled selectively at the Customer's request.

7. TOTAL QUALITY

Each FlowStart assembled by Carlor Engineering is controlled and tested before leaving the factory. Carlor Engineering runs the following test on each FlowStart:

- Heating test.
- Test of the circulating pump.
- Air pressure test of the heating body.
- Test of electrical insulation.

You will find in the packaging a check list of all the tests undergone on your FlowStart. Keep this list carefully.

8. WARRANTY

All our devices FlowStart are guaranteed against all manufacturing errors over a 2 years period, starting at the invoice date and following general sales conditions. This warranty is voided in each of the following situations:

- The device was transformed or modified without permission of Carlor Engineering
- Installation and use are against the guidelines of FlowStart
- The heater is damaged by impurities or grimes.

Our warranty covers exclusively the changing of the standard installation or replacement of the damaged parts. Are not taken under warranty: wrong installation or use, costs for assembling and disassembling the heater, costs for assembling or disassembling the installation, shipment costs.

Manufactured in Belgium by:

Carlor Engineering S.A.
Avenue Albert 1^{er}, 87
B-4030 Grivegnée
Belgique
Tel : +32 4 384 01 97 Fax : +32 4 367 16 66
info@carlor.com www.carlor.com

Carlor Engineering S.A.

Avenue Albert 1^{er}, 87 B-4030 Grivegnée Belgium

Tél. : +32 (0)4 384 01 97
www.carlor.com

Fax : + 32 (0)4 367 16 66
info@carlor.com