



DSEM835

PROGRAMMABLE DISPLAY FOR USE IN VEHICLES AND OFF-HIGHWAY MACHINERY



KEY FEATURES / SUMMARY

- Robust HMI/programmable display specifically designed for mobile applications
- Optically bonded 3.5" colour screen for harsh environments
- Auto on / off heated display for use in low temperatures
- Powerful processor with Cortex M7 400 MHz clock speed
- 512 KB of SDRAM and 8 MB of flash storage
- 4 configurable inputs, digital and analogue capability
- 3 configurable digital outputs
- 1 VREF output (to power sensors)
- CAN interfaces, J1939 and Raw CAN
- PCAN interface for programming
- Flexible user programming via CODESYS 3.5
- IP67 protection / NEMA 6

ADDITIONAL HARDWARE

Deutsch connector A, 18 way complete with pins
E050 connector harness
E050 configuration harness
PCAN USB PC configuration interface

DSE PART

007-850
016-177
016-176
016-179

OVERVIEW

DC SUPPLY

8 V DC to 32 V DC

CURRENT CONSUMPTION

OPERATING CURRENT
< 1000 mA at 12 V and 24 V without external loads

DISPLAY

320 px x 240 px
24 bit colour
Optically bonded

INPUTS (4)

CONFIGURABLE INPUTS 1 to 4
Configurable as: digital, current, voltage, resistance
0 V to 10 V
0 mA to 20 mA
0-3 kΩ

OUTPUTS (3)

DC OUTPUTS 1 to 3
1 A continuous at supply voltage

VREF OUT

100 mA at 10 V / 5 V

INTERFACES

CAN 1

CAN Interface 2.0 A/B, ISO11898
50 kbits/s... 1 Mbit/s
SAE J1939 or Raw CAN
Configurable internal software 120 Ω resistor

DIMENSIONS

OVERALL (W x H x D)

112.5 mm x 115 mm x 49 mm
4.43" x 4.53" x 1.93"

PANEL CUT-OUT

80 mm / 3.15" Diameter

TORQUE SETTING

8 Nm / 5.9 ft-lb

WEIGHT

< 1 kg

STORAGE TEMPERATURE RANGE

-40 ° C to +85 ° C
-40 ° F to +185 ° F

HEATED DISPLAY OPERATING RANGE

Turns on at -25 ° C / -13 ° F
Turns off at -5 ° C / 23 ° F

OPERATING TEMPERATURE RANGE

-40 ° C to +85 ° C
-40 ° F to +185 ° F

PROTECTION RATING

IP67 / NEMA 6 (with mating connectors)

RELATED MATERIALS

TITLE

M835 Operators Manual
M835 Installation Instructions

PART NO.

057-313
053-250

DEEP SEA ELECTRONICS LTD UK

Highfield House, Hunmanby Industrial Estate, Hunmanby YO14 0PH
TELEPHONE +44 (0) 1723 890099 **FACSIMILE** +44 (0) 1723 893303
EMAIL sales@deepseaelectronics.com **WEBSITE** www.deepseaelectronics.com

DEEP SEA ELECTRONICS INC USA

3230 Williams Avenue, Rockford, IL 61101-2668 USA
TELEPHONE +1 (815) 316 8706 **FACSIMILE** +1 (815) 316 8708
EMAIL usasales@deepseaelectronics.com **WEBSITE** www.deepseaelectronics.com



Technical Data

DSEM835

Supply		Connector A
Operating voltage	8 V DC to 32 V DC	Pin 7
Unit power supply maximum current consumption, full backlight (no external loads)	< 1000 mA at 12 V and 24 V	
Fusing		Connector A
Unit power supply external protection fuse rating	3 A	Pin 7
Housing		
PC PBT alloy plastic resin		
Dimensions		
Overall (W x H x D) 112.5 mm x 115 mm x 49 mm (4.43" x 4.53" x 1.93")		
Weight		
< 1 kg		
Temperature		
Operating temperature	-40 °C to +85 °C / -40 °F to +185 °F	
Storage temperature	-40 °C to +85 °C / -40 °F to +185 °F	
Protection Rating		
	IP67 (mating connectors)	
	NEMA 6 (mating connectors)	
Display		
Resolution, pixel	320 px x 240 px	
Colour	24 bit	
Format	3.5" diagonal	
Mounting	Optically bonded	
Illumination	LED (lifetime > 30,000 hrs)	
Connectors		
Connector A	18 pin TE connectivity DT16-18SA-K004	
Digital Inputs		Connector A
Digital inputs configured high or low		Pin 5, 6, 12, 18
High level voltage threshold	Configurable	
Low level voltage threshold	Configurable	
Analogue Voltage Inputs		Connector A
0 V to 5 V programmable voltage range	0 V to 5 V	Pin 5, 6, 12, 18
0 V to 10 V programmable voltage range	0 V to 10 V	
0 V to 32 V programmable voltage range	0 V to 32 V	
Voltage measurement resolution	12 bits	
Voltage measurement accuracy	± 1% FSD	
Voltage measurement input resistance	≥ 7.5 kΩ	
Voltage measurement sampling rate	500 Hz	
FSD = Full Scale Deflection		



DSEM835

Analogue Current Inputs		Connector A
Current measurement direction	Current sink only	Pin 5, 6, 12, 18
Current measurement ranges	0 mA to 20 mA	
	4 mA to 20 mA	
Current measurement resolution	12 bits	
Current measurement accuracy	± 1% FSD	
Current measurement input sink resistance	150 Ω ± 1%	
Current measurement sampling rate	500 Hz	
FSD = Full Scale Deflection		
Analogue Resistive Inputs		Connector A
Resistance measurement range	0 Ω to 3200 Ω	Pin 5, 6, 12, 18
Resistance measurement source voltage	12 V maximum	
Resistance measurement current	3 mA	
Resistance measurement resolution	12 bits	
Resistance measurement accuracy	± 1% FSD	
Resistance measurement sampling rate	500 Hz	
FSD = Full Scale Deflection		
Digital Outputs High Side		Connector A
Switching current	1 A	Pin 14, 15, 16
Digital output active high 'ON' state internal voltage drop at rated current	< 100 mV	
Digital output active high 'OFF' state leakage current	< 120 µA at 24 V	
Reference Voltage		Connector A
Reference voltage output	Programmable 5 V or 10 V, 100 mA accuracy ±5%	17
		VRef GND Pin 13
CAN Interfaces		Connector A
Number of CAN ports	1	Pin 2, 3, 4 / 8, 9, 10
Supported protocols	J1939	
	Raw CAN	
Supported programmable baud rates	50 kbit/s, 125 kbit/s, 250 kbit/s, 500 kbit/s, 800 Mbit/s, 1 Mbit/s	Programmable using PCAN Interface
Processor		
STM 32h743	Cortex ARM M7	
	400 MHz	
Memory		
Flash	8 MB	
RAM	288 KB	
Non Volatile	16 KB	



DSEM835

Environmental and Testing		
Electro Magnetic Compatibility	Noise immunity Emission standard Road vehicles Road vehicles - electrical disturbances from conduction and coupling. Part 3: Electrical transient transmission by capacitive and inductive coupling via lines other than supply lines	BS EN 6100-6-2 BS EN 6100-6-4 ISO 11452 ISO 7637-3: 2016
Electrical Safety	Safety requirements for electrical equipment for measurement, control & laboratory use Part 1: General requirements Part 2-030: Particular requirements for testing measuring circuits	BS EN 61010 BS EN 61010:2010 BS EN 61010-2-30: 2010
Electrical tests	Road vehicles - environmental conditions and testing for electrical & electronic equipment Part 2: Electrical loads 4.6.3 Starting profile 4.6.4 Load dump	ISO 16750-2: 2012
Climatic tests	Damp heat, cyclic upper temperature 55°C, number Damp heat, steady state test temperature 40 °C / 93% RH	EN 60068-2-30 EN 60068-2-78
Mechanical tests	Part 2-6: Tests - Test Fc: Vibration (sinusoidal) Part 2-27: Tests - Test Ea: Shock	EN 60068-2-6 EN 60068-2-27
Temperature	Ab / Ae cold test -40 °C (-40 ° F) Bb / Be dry heat +85 °C (185 ° F)	
Chemical	Chemical testing for electrical and electronic equipment - road vehicles	ISO 16750-5
Degrees of protection provided by enclosures	IP67 / NEMA 6	BS EN 60529



DSEM835

PROGRAMMABLE DISPLAY FOR USE IN

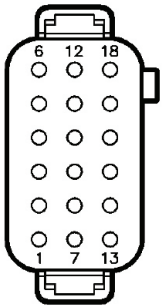
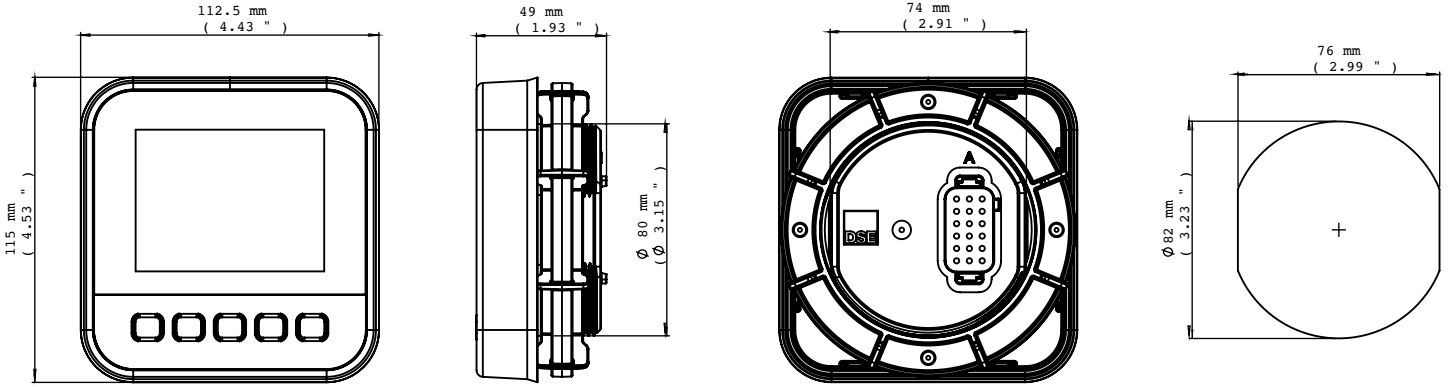

Connector A

PIN	DESCRIPTION
1	Batt GND
2	CAN Screen
3	CAN L In
4	CAN H In
5	Input 4
6	Input 1
7	VDC Batt +
8	CAN Screen
9	CAN L Out
10	CAN H Out
11	GND
12	Input 2
13	VREF GND
14	Output 1
15	Output 2
16	Output 3
17	VREF Out
18	Input 3